

# Vacuum Circuit Breaker Model : Application Case to Motors Switching

C. Vollet, B. de Metz-Noblat

**Abstract--** In an industrial plant equipped with HV motors, several severe stator failures occurred in spite of the installation of surge arresters. All of these motors were switched with vacuum circuit breakers.

The purpose of this paper is to demonstrate the necessity of complementary protection against overvoltages by adding C-R (capacitor - resistor) surge suppressors.

This paper will first give an overview of the types of switching surges that can occur in this network configuration. Secondly, network simulations using EMTP/ATP software are presented, including a complete simulation of a vacuum circuit breaker. The object of these simulations is to calculate the overvoltages created during motor switching, to study the evolution of these overvoltages as a function of cable length and motor power, and to check if additional protection needs to be installed on these motors. The comparison is made between the simulated voltages and the motors withstand voltage capability defined in the IEC 60034-15. This comparison is done not only with magnitude criteria but also with time rise.

It can be concluded that even with two MOA (Metal-Oxide Arrester) surge arresters the protection of the motor is not guaranteed and that full motor protection is provided by installing C-R surge suppressors thus eliminating multiple reignitions.

**Keywords:** Switching overvoltage, vacuum circuit breaker, MOA surge arrester, C-R surge suppressor, motor, EMTP/ATP.

## I. INTRODUCTION

IN a desalination plant equipped with 32 HV motors (11 kV), several severe stator failures occurred. At least 3 motors have developed stator failures during commissioning tests, then one failed during operation in spite of the installation of MOA surge arresters.

All of these motors were switched with vacuum circuit breakers, and thus the first assumption was that the stator faults were a result of exposure to steep fronted switching surges. These surges cause severe stress on the stator windings insulation because of the non-uniform distribution of the voltage across the windings. Both opening and closing operations could generate switching overvoltages with large amplitude and high frequencies. If the switching overvoltage amplitude exceeds the basic insulation level (BIL) of the motor, overvoltage protection must be installed.

The purpose of this paper is to demonstrate, in the case of this desalination plant, the necessity of complementary protection against overvoltages by adding C-R surge suppressors.

The paper will first give an overview of the types of switching surges that can occur in this network configuration i.e. current chopping and voltage escalation at de-energization and re-ignition at energization.

Secondly, network simulations using EMTP/ATP software are presented, including a complete simulation of the vacuum circuit breaker. This model takes into account the chopping current, the slope of recovery strength and the current slope that the vacuum switch is able to interrupt. The object of these simulations is to calculate the overvoltages created during motor switching, to study the evolution of these overvoltages as a function of cable length and motor power, and to check if some additional protection needs to be installed on these motors.

The maximum overvoltages obtained in the simulations often exceeds the withstand level of the motor insulation, the comparison is done not only with magnitude criteria but also with time rise.

It can be concluded that even with two MOA surge arresters, one located at the load terminals of the vacuum circuit breaker and the other located at the motor terminals, the protection of the motor is not guaranteed.

Full motor protection can be provided by installing C-R surge suppressors and by keeping the MOA surge arresters on all the motors.

## II. TYPES OF OVERVOLTAGES ASSOCIATED WITH VACUUM SWITCHING

The subject of switching surge overvoltages associated with vacuum circuit breakers has been discussed in many technical papers [1]-[3]. Therefore the aim of this chapter is to clarify only the involved phenomena leading to the most severe transients and to describe them in some detail.

### A. Current Chopping (opening)

Current chopping ( $I_0$ ) refers to the premature suppression of the power frequency current before normal current-zero in the vacuum circuit breaker. Depending on the load's inductance ( $L_b$ ), a magnetic energy remains trapped in the load circuit.

The maximum voltage at the load level can be estimated with the approximation that the trapped magnetic energy ( $1/2 L_b I_0^2$ ) will be converted into electrical energy in the parasitic capacitance ( $C_b$ ). So the estimation of the maximum chopping overvoltage ( $\hat{U}_m$ ) is :

---

Caroline Vollet is with Schneider Electric, P&E Center, Grenoble – France (e-mail: caroline.vollet@fr.schneider-electric.com).

Benoit de Metz Noblat is with Schneider Electric, P&E Center, Grenoble – France (e-mail: benoit.de-metz-noblat@fr.schneider-electric.com).

$$\frac{1}{2}Cb\dot{U}_m = \frac{1}{2}LbI_0^2 + \frac{1}{2}CbU_{pf}^2 \Rightarrow \dot{U}_m = \sqrt{U_{pf}^2 + I_0^2 \frac{Lb}{Cb}}$$

where  $U_{pf}$  is the power frequency voltage at interruption

For vacuum circuit breakers, the chopping current is determined mostly by the contact material and is typically 2 to 10 A. Data published in [2] indicates that the maximum overvoltage created by current chopping never exceeds the IEEE motor impulse voltage withstand recommendation [5]. Therefore, in general, overvoltages at current chopping do not need surge protection (see chapter V.A).

### B. Voltage Escalation (opening)

Voltage escalation arises after reignition of the circuit breaker following switching off after a short arcing time. Reignition can occur when contact separation takes place near current zero, with the contact gap too small to withstand the Transient Recovery Voltage (TRV). As a result network capacitances on both sides of the breaker discharge over the inductance, causing a high frequency oscillating current (typically 100 – 200 kHz) through the breaker. The vacuum circuit breaker is able to interrupt this current at high frequency current zero. A new TRV will develop over the breaker steeper and higher than the previous one. If the separating contacts have not yet gained sufficient dielectric strength, there will be a new reignition. This sequence of events may be repeated several times (up to 10) with increasing amplitude. The process will stop only when the breaker gap strength reaches a value higher than the TRV.

### C. Repetitive Pre-Ignition (closing)

During the closing operation, several pre-ignitions can occur if the gap between the contacts breaks down before galvanic contact is established. However, pre-ignition is less severe than multiple reignition, first because the contact gap at the first pre-strike is very small and second because the peak value of the steep waves decreases in time, because the contacts approach.

### D. Virtual Current Chopping (opening)

Virtual current chopping is caused by an interaction between two phases, dependant upon the capacitive coupling between the phases. If a reignition in one phase (phase A for example) causes a high frequency current, a part of this transient current may flow in phase B and C via the network capacitances. This could cause a current zero crossing in these two phases ; this forced current-zero phenomenon is virtual current chopping (see Fig. 1).

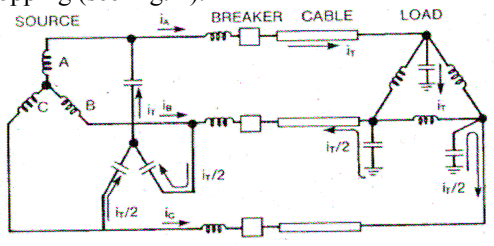

Fig. 1. Circuit demonstrating how the high frequency current resulting from a reignition in one phase couples into the other phases to produce the conditions for virtual current chopping.

Compared with normal current chopping, the virtual current chopping can be much higher and also the overvoltages between phases B and C can be up to twice the overvoltage from phase to ground on these phases.

## III. DESCRIPTION OF THE NETWORK AND MODELS

On Fig. 2, it is shown the simplified single line diagram of the simulated electrical network of the desalinization plant.

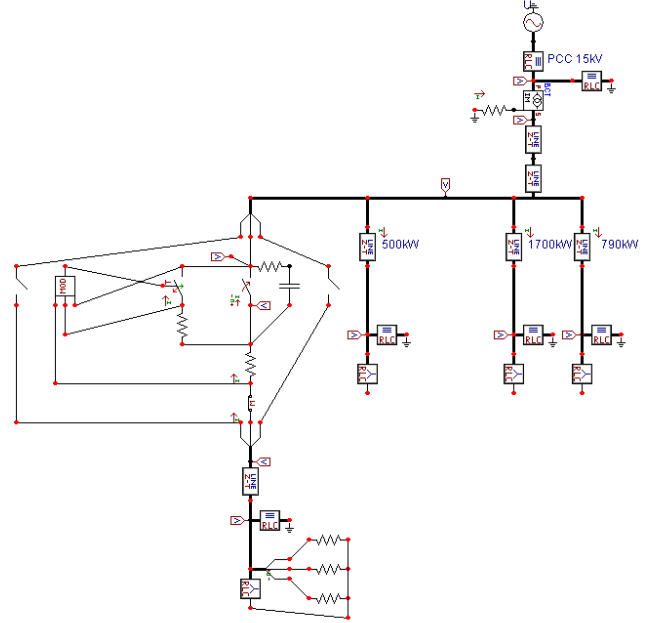

Fig. 2. Simplified simulated single line diagram

The software used to simulate this network is ATP (Alternative Transients Program). ATP is primarily a simulation program for the electrical power industry.

The technical data of equipment taken into account are :

### A. Network Supply 15 kV and 47 MVA 15/11 kV Transformer

Parameters for the equivalent source were varied to cover maximum and minimum short circuit power and to take into account the earthing system.

### B. Cable Data

A model with distributed parameters was used to represent all the cables in order to take into account the high frequency behaviour of cables.

TABLE I  
CABLE DATA

Cable	size in sq.mm	length in m	surge impedance in ohm	propagation velocity in km/s
between the transformer and the main busbar	3#1Cx500	215	8.55	89 10 <sup>3</sup>
between the main and the motors busbars	4#3Cx240	450	7	94 10 <sup>3</sup>
between the motors busbar and the motors	3Cx150	see motors characteristics	28	90 10 <sup>3</sup>

### C. Motor Data

All of the 32 motors of the switchboard were modelled by an equivalent circuit ( $R+jX$ ) which represents the motor in the starting conditions. When a vacuum circuit breaker interrupts a running motor, no high overvoltage is expected because the emf produced by the running motor opposes the source voltage resulting in a very small TRV across the opening contacts.

To ensure robustness to sensitivities associated with variations in cable length and motor size, consideration was given to the largest and the smallest motors and the longest and the shortest cable feeders.

TABLE II  
MOTORS DATA

Motor In kW	rated current (Amps)	running power factor	starting current (Amps)	starting power factor	parallel capacitance	cable length (m)
500	30.6	0.91	160	0.163	frequency = 15 kHz	248 – 239 – 216
790	50.5	0.86	245	0.16	frequency = 15 kHz	140
1650	100	0.89	606	0.189	frequency = 15 kHz	113 – 126 – 139 – 152

### D. Vacuum Circuit Breaker Data

A simple switch model, controlled by means of a logic imposed in MODELS (ATP), simulates the multiple reignitions and the arc created (see Fig. 3).

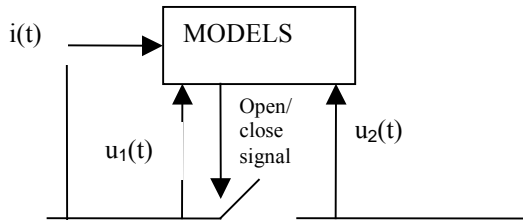

Fig. 3. Model of Vacuum Circuit Breaker

The model takes into account the following characteristics :

- The dielectric recovery strength between contacts when opening,
- The ability of the vacuum circuit breaker to chop the current before its natural zero,
- The high frequency quenching capability of the circuit breaker. In fact, we fixed the number of the HF current zero crossing before opening.

The control logic implemented in MODELS is the following :

- After mechanical separation of the breaker contacts, it is considered that the dielectric strength between them rises linearly with a definite slope.
- The voltage between the contact in each instant,  $u(t_1)$ - $u(t_2)$ , is compared with the withstand voltage (defined by the above mentioned straight rise) and in case it is surpassed, a closing signal is given to the switch, so a reignition of the arc is simulated.

If the reignition occurs, then two conditions should be fulfilled for the circuit breaker to interrupt again the current :

- The number of HF current zero crossing must be over the fixed limit and
- The instantaneous value must be smaller than that which the breaker is able to chop.

If these two conditions are fulfilled, an opening signal for the switch is produced.

The preceding logic is repeated for each time step and so it's possible to simulate the multiple reignitions phenomena and the voltage escalation.

For the present study, the following values are used, based on our know-how and the technical papers :

- Slope of recovery strength = 20 or 40 kV/ms,
- Chopping current = 5 or 8 A,
- Number of HF current zero crossing = 3,
- Average contact opening velocity = 1 m/s,
- Total travel of the moving contact = 5 mm.

### E. Surge Arresters Data

The MOA surge arresters are located at the load terminals of the vacuum circuit breaker and in some cases directly on the motor terminals.

The arresters are represented as exponential MOA surge arrester  $R(i)$ , i.e. the non linear V-I characteristic is approximated by a number of exponential segments determined with the following points (Type 92 element in EMTP/ATP software):.

TABLE III  
ARRESTERS DATA

Arrester connected to motors busbar		Arrester connected to the motors	
Current (A)	Voltage (V)	Current (A)	Voltage (V)
0.003	21600	0.0001	18400
0.03	22500	0.001	22925
10	26000	0.01	23850
500	42100	0.1	24000
1500	46000	1	24288
3000	49000	10	25700
5000	52000	100	27600
10000	57500	1000	31800
20000	65400	10000	36800
40000	76900		

The arresters are connected to the earth with a 1  $\Omega$  resistor in order to be more realistic.

### F. C-R Surge Suppressors Data

The C-R surge suppressor is composed with a resistor connected in series with a surge capacitor. The value of the capacitor is taken to 0.2 or 0.3  $\mu$ F and the resistor must be at least equal to 30  $\Omega$ .

## IV. OVERVOLTAGE EFFECTS ON MOTOR INSULATION

In order to examine the effects of switching overvoltages on motor insulation, these overvoltages are compared to the rated insulation levels for rotating machines given in the IEC 60 034-15 International Standard [5].

For 11 kV motors :

- Rated lightning impulse withstand voltage (1,2/50  $\mu$ s wave) = 49 kV peak,
- Rated steep-front impulse withstand voltage (0.2  $\mu$ s wave) = 32 kV peak,
- Rated power frequency withstand voltage (50 Hz) = 23 kV rms.

For the motors, the rated steep-front impulse withstand voltage is the impulse test of the interturn insulation. The voltage is applied between the two terminals of the coils. In the simulations, it is equivalent and has to be compared to the voltage between phase and neutral.

The rated lightning impulse withstand voltage is the impulse test of the main insulation. The voltage is applied between the coils terminals and earth. In the simulations, it is equivalent and has to be compared to the voltage between phase and earth.

The comparison between the simulated overvoltages and the standard withstand voltage is done not only with magnitude criteria but also with time rise. The overvoltage curve obtained by simulation must be within the envelope defined by IEC 60 034-15 (see Fig. 4 and 5).

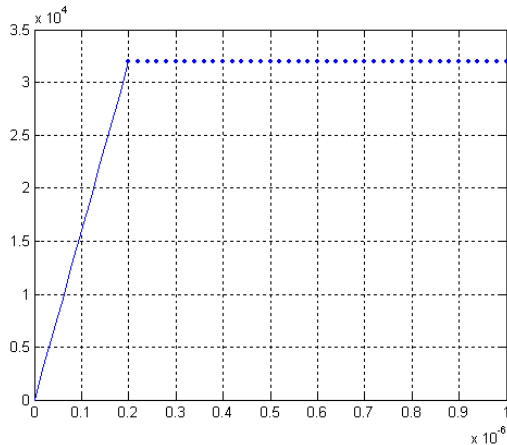

Fig. 4. Interturn insulation 32 kV (V1)

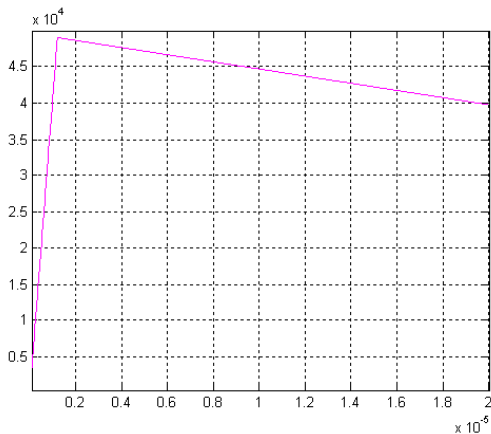

Fig. 5. Main insulation 49 kV (V2)

When the simulated overvoltages magnitude is over 32 kV for V1 or 49 kV for V2, it is obvious that the overvoltage is outside the envelope and there is no need of time rise checking.

When the simulated overvoltages magnitude is below 32 kV for V1 or 49 kV for V2, then a graphical check for time rise is systematically done.

## V. TRANSIENT SIMULATIONS

### A. Current Chopping (opening)

In these simulations we have modeled only current chopping without reignition.

The results are presented for the motor with the lowest power and with the shortest cable, i.e. 500 kW motor supplied via 216 m cable and for a chopping current of 8 Amps. The maximum overvoltage is around 22.2 kV peak. The frequency observed on the voltage curves corresponds to the resonance between the motor inductance and the cable capacitance.

Fig. 6 gives the overvoltage at motor terminal (phase to earth) and Fig. 7 shows the current chopping in the circuit breaker.

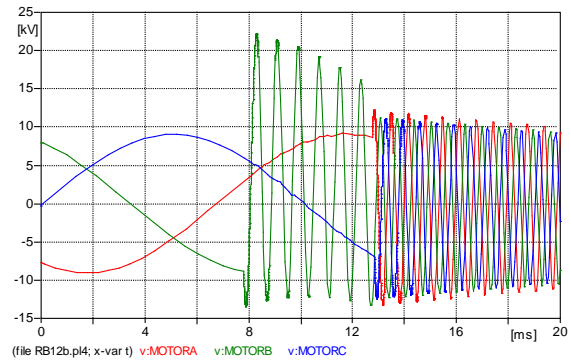

Fig. 6. Voltage at motor terminal (single phase voltage): 22200 Vpeak with a frequency of 1500 Hz

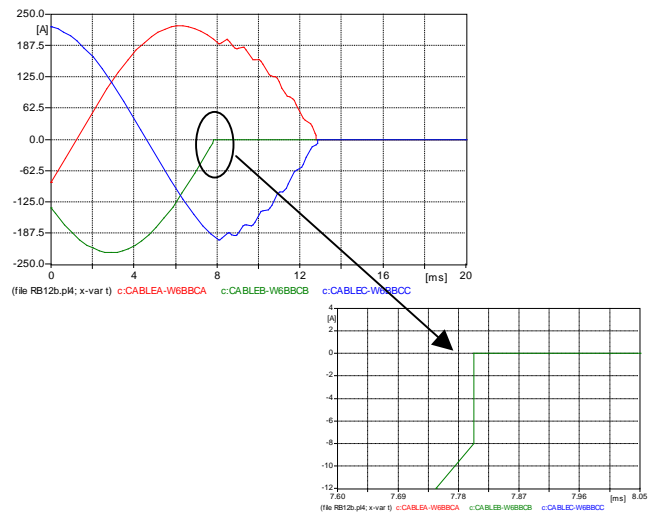

Fig. 7. Current in the motor circuit breaker – current chopping = 8 Amps

These simulations show that even with a current chopping of 8 Amps, the highest generated phase to earth overvoltage is well within the withstand voltage of all equipment. At these relatively low levels of overvoltage, the arresters have little effect on the level of switching overvoltages.

The obtained results are in accordance with the results described in the technical publications [4], i.e. current chopping overvoltages remain limited nowadays and the worst

case is with short cable and low motor power.

### B. Voltage Escalation (opening)

In these simulations, we have modelled current chopping with reignition : the switch model simulates the multiple re-ignitions of the arc in the vacuum circuit breaker.

#### 1) Without any MOA Surge Arrester :

When there is no MOA surge arrester connected, the overvoltage due to multiple re-ignitions is well over the withstand level of the motor insulation.

#### 2) With MOA Surge Arrester at Load Terminal of the Vacuum Circuit Breaker :

When there is only one MOA surge arrester connected at the load terminal of the vacuum circuit breaker, the overvoltage at the arrester connection point is limited to the residual voltage of this arrester. But due to the wave reflections in the cable, the overvoltage at the motor terminal is above the withstand level of the motor insulation.

#### 3) With MOA Surge Arresters at Load Terminal of the Vacuum Circuit Breaker and at the Motor Terminal :

These simulations show that even with two arresters, one located between the vacuum circuit breaker and the cable and the other located at the motor terminal, the protection of the motor is not guaranteed.

The maximum overvoltage obtained in the simulations is very near or even over the withstand level of the motor insulation.

Fig. 8 gives the overvoltage at motor terminal (phase to earth), the MOA action can be clearly seen on this figure.

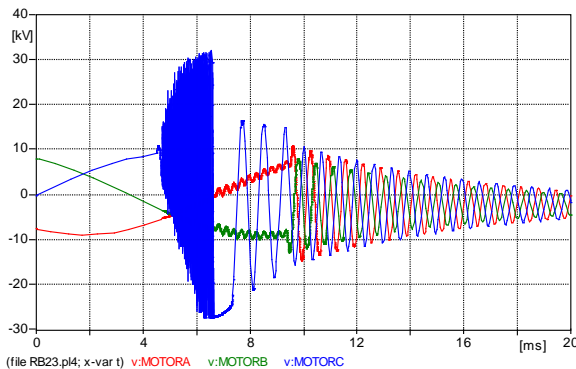

Fig. 8. Voltage at motor terminal (single phase voltage): 32k Vpeak

The phase to neutral voltage at motor terminal is given by Fig. 9, the maximum value is about 24 kV peak.

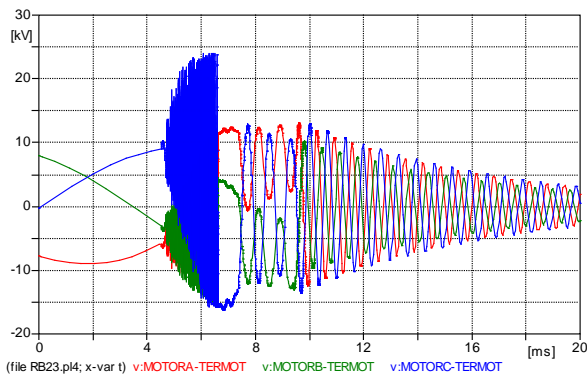

Fig. 9. Voltage across the motor winding (phase to neutral voltage): 24k Vpeak

So, if these overvoltages are compared only with magnitude criteria, it can be said that the motor protection is correct. But if a graphical check for time rise is made taking into account the envelope defined by IEC 60 034-15, the conclusion can be different. Fig. 10 gives the two latest re-ignitions for the single phase voltage and Fig. 11 shows the comparison between the simulated overvoltage and the envelope defined by IEC 60 034-15.

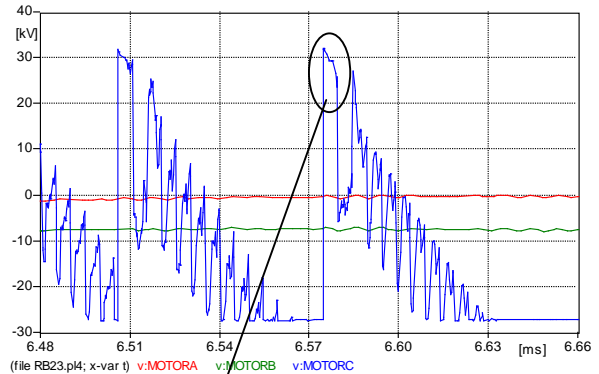

Fig. 10. Voltage at motor terminal (single phase voltage) : Zoom on the two latest re-ignitions

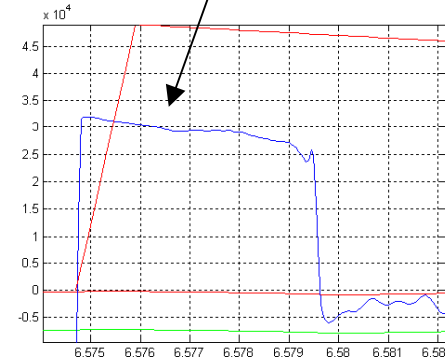

Fig. 11. Comparison between simulated overvoltages (in blue) and IEC envelope (in red)

On Fig. 11, the time rise is measured at 0.1  $\mu$ s.

The conclusion is that even with arresters located at the motor terminal, the motor is not correctly protected and some very high frequency overvoltages can affect the motor and exceed its withstand level.

Furthermore, the arresters do not limit the multiple reignitions associated with the vacuum circuit breakers.

On the other hand, the properly sized C-R surge suppressors eliminate multiple reignitions and voltage escalation and limit the overvoltages within the withstand levels for the motors.

Fig. 12 and Fig. 13 gives respectively the single phase voltage and the phase to neutral voltage with C-R surge suppressors on motor terminal.

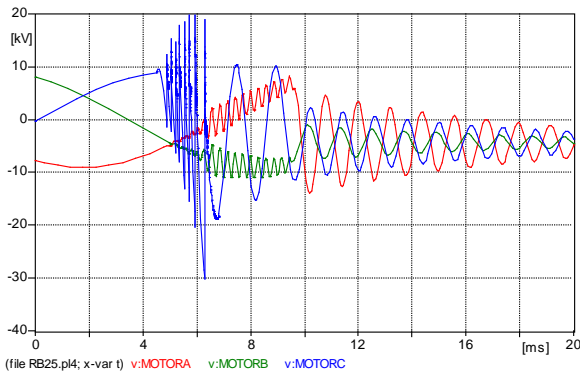

Fig. 12. Voltage at motor terminal (single phase voltage): 26k Vpeak with a frequency around 1kHz

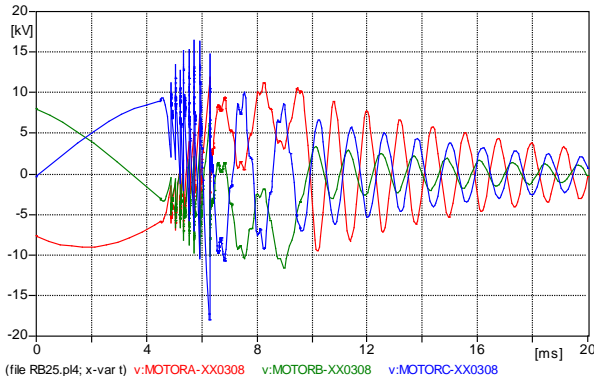

Fig. 13. Voltage across the motor winding (phase to neutral) 15k Vpeak with a frequency around 1kHz

### C. Circuit Energization

In these simulations, we model the different circuit energization. The level of overvoltage during switching on is considered to be a statistical quantity on 100 simulations. In the studies, the circuit breaker is randomly permitted to close at any point on the 50 Hz waveform with all poles closing within a random 2.5 ms pole window to account pole scatter. This permits us to find the max overvoltage that might occur in motor energization.

These simulations show that the MOA surge arresters, one located between the vacuum circuit breaker and the cable and one located at the motor terminal, are necessary to be sure of the protection of the motor.

Without these MOA surge arresters or with only the MOA surge arrester located between the vacuum circuit breaker and the cable, the maximum overvoltage obtained in the simulations is very near or even over the withstand level of the motor insulation.

## VI. CONCLUSIONS

The HV motors failures occurred in a desalinization plant in spite of the installation of MOA surge arresters can be explained by the voltage escalation phenomenon developed in the vacuum circuit breaker. A model of vacuum circuit breaker was developed and used in ATP in order to study overvoltages resulting from current chopping and voltage escalation.

The results obtained may be summarized as follows :

- The overvoltages due to simple current chopping are within the withstand levels of the motors

- The phenomenon of multiple reignition and voltage escalation produced overvoltages that could be over the withstand level of the motors. A complete comparison must be made not only according magnitude criteria but also with time rise. In our case, even if the magnitude of the simulated overvoltage was under the standard limit, the time rise was shorter than the wave defined in the IEC 60 034-15 standard.

Full motor protection can be provided by installing C-R surge suppressors on all the motors.

## VII. REFERENCES

- [1] J. F. Perkins, "Evaluation of switching overvoltages on medium voltage power systems," *IEEE Trans. Power Apparatus and Systems*, vol. PAS-101, pp. 1727-1734, June. 1982.
- [2] S. H. Telander, M. R. Wilhelm, K. B. Stump, "Surge limiters for vacuum circuit breakers," *IEEE Trans. Industry Applications*, vol. 24, pp. 554-559, July. 1988.
- [3] S. M. Wong, L. A. Snider, "Overvoltages and reignition behavior of vacuum circuit breaker," in *Proc. 2003 International Conf. On advances in power system control, operation and management.*, pp. 653-658.
- [4] J. D. Gibbs, D. Koch, P. Malkin and K. J. Cornick, "Comparison of performance of switching technologies on E CIGRE motor simulation circuit," *IEEE Trans. Power Delivery*, vol. 4, pp. 1745-1750, July. 1989.
- [5] *IEC 60 034-15 Impulse voltage withstand levels of rotating a.c. machines with form-wound stator coils*, 1995.

## VIII. BIOGRAPHIES

Caroline Vollet received her Electrical Engineering degree from the National Polytechnic Institute of Grenoble in 1988. She joined Merlin Gerin (now Schneider Electric) in 1989. She is currently working on electrical network analyses such as stability, harmonic and overvoltages studies. She has been personally involved in several instances of equipment failure or malfunctioning in different kind of industrial plants .

Benoit de Metz-Noblat received his Electrical Engineering degree from the Ecole Supérieure d'Electricité (France) in 1974. He worked first for Saint Gobain as electrical new projects & maintenance manager. He joined Merlin Gerin (now Schneider Electric) in 1986. He is a member of the Electrical Network competence group that studies electrical phenomena concerning the operation of networks and their interaction with devices and equipment.